

Table III. Enthalpies of Trifluoroacetylation of *n*-Hexenes

compd	<i>n</i> ^a	ΔH_r (cal/mol)	ratio ^b	ΔH_{cor} (cal/mol) ^c	$\Delta\Delta H$ (cal/mol)
1-hexene	10	-11 985 ± 13	1.34 ± 0.12	-11 994 ± 23	0
<i>cis</i> -2-hexene	6	-10 104 ± 24	0.91 ± 0.06	-10 130 ± 28	1864 ± 36
<i>trans</i> -2-hexene	6	-9 358 ± 28	0.74 ± 0.04	-9 393 ± 30	2601 ± 38
<i>cis</i> -3-hexene	7	-10 584 ± 22	0.69 ± 0.07	-10 622 ± 29	1372 ± 37
<i>trans</i> -3-hexene	6	-9 625 ± 22	0.77 ± 0.08	-9 658 ± 29	2336 ± 37

^a Number of runs. ^b Ratio of 2-hexyl trifluoroacetate/3-hexyl trifluoroacetate observed 10 min after mixing. ^c Corrected to the equilibrium mixture.

Table IV. Enthalpies of Formation of Liquid *n*-Hexenes (kcal/mol)

compd	lit. ^a	adjusted ^a
1-hexene	-17.29 ± 0.29	-17.29 ± 0.20
<i>cis</i> -2-hexene	-20.05 ± 0.32	-19.15 ± 0.20
<i>trans</i> -2-hexene	-20.44 ± 0.38	-19.89 ± 0.20
<i>cis</i> -3-hexene	-18.87 ± 0.32	-18.66 ± 0.20
<i>trans</i> -3-hexene	-20.57 ± 0.32	-19.63 ± 0.20

^a The value for 1-hexene derived from combustion calorimetry was taken as correct, and this was combined with the observed differences found in the trifluoroacetylation studies.

rate of the reaction.¹⁴ We have found that the acid-catalyzed trifluoroacetylation of alkenes¹⁵ would proceed rapidly at 25 °C. If the solvent is made up including 0.25 M trifluoroacetic anhydride, it may also be used to measure the enthalpy of conversion of alcohols to trifluoroacetates. The sum of the reactions in Scheme I will lead to the enthalpies of hydration.

Initially, methanesulfonic acid was used as the catalyst. This gave a satisfactory reaction rate using 0.25 M acid. However, an examination of the NMR spectrum of the solution shortly after adding 1-hexene indicated that the major products were methanesulfonates, which were then slowly converted to the trifluoroacetates. This problem was eliminated by using trifluoromethanesulfonic acid as the catalyst. Here, only trifluoroacetates were observed. The reaction occurred rapidly over a wide range of acid catalyst concentration, and the enthalpy of reaction was found to be independent of the acid concentration in the range 0.002–0.05M. The enthalpy of reaction also was found to be independent of the amount of alkene used.¹⁶

The *n*-hexenes were studied in the initial phase of this investigation. They were chosen because enthalpies of formation of the *n*-hexenes^{4,17} as well as that of 2-hexanol¹⁸ are available from enthalpy of combustion measurements. A comparison of the present results with these data was expected to serve to confirm the applicability of the experimental method.

It is known that the *n*-hexenes will give a mixture of 2-trifluoroacetates and 3-trifluoroacetates.¹⁵ In order to interpret the results of the calorimetric studies, it was necessary to know the difference in energy between the two esters. This could readily be determined since the esters undergo equilibration at a reasonable rate in the presence of methanesulfonic acid. The ratio of esters could be measured by gas chromatography giving the data shown in Table I. These data lead to $\Delta H = 172 \pm 21$ cal/mol with the 2 isomer being the more stable.

The enthalpies of trifluoroacetylation were determined using the automated reaction calorimetry system previously described.¹⁹

(14) Levy, J. B.; Taft, R. W., Jr.; Aaron, D.; Hammett, L. P. *J. Am. Chem. Soc.* **1951**, *73*, 3792. Taft, R. W., Jr.; Levy, J. B.; Aaron, D.; Hammett, L. P. *Ibid.* **1952**, *74*, 4735.

(15) Peterson, P. E. *J. Am. Chem. Soc.* **1960**, *82*, 5834. Peterson, P. E.; Allen, G. *J. Org. Chem.* **1962**, *27*, 1505.

(16) It is conceivable that some hexene underwent acid-catalyzed polymerization shortly after the ampule was broken and before it had been well mixed. Once the hexene was mixed, its concentration would be approximately 0.01 M and polymerization would not occur. If polymerization were occurring in the calorimeter, its rate would be dependent on the acid and hexene concentrations. Therefore, the amount of polymerization which occurred before ceasing due to dilution would vary with these concentrations, and the heat evolved would vary. This was not observed.

(17) Bartolo, H. F.; Rossini, F. D. *J. Phys. Chem.* **1960**, *64*, 1685.

(18) Sachek, A. I.; Peshchenko, A. D.; Andreevskii, D. N. *Russ. J. Phys. Chem.* **1974**, *48*, 617.

(19) Wiberg, K. B.; Squires, R. R. *J. Chem. Thermodyn.* **1979**, *11*, 773.

Table V. Enthalpies of Formation of Liquid 1-*n*-Alkenes (kcal/mol)

compd	obsd	calcd	dif
1-butene	-5.12 ± 0.13	-5.27	0.15
1-pentene	-11.42 ± 0.32	-11.27	-0.15
1-hexene	-17.29 ± 0.29	-17.25	-0.04
1-heptene	-23.33 ± 0.25	-23.24	-0.09
1-octene	-29.11 ± 0.30	-29.23	0.12

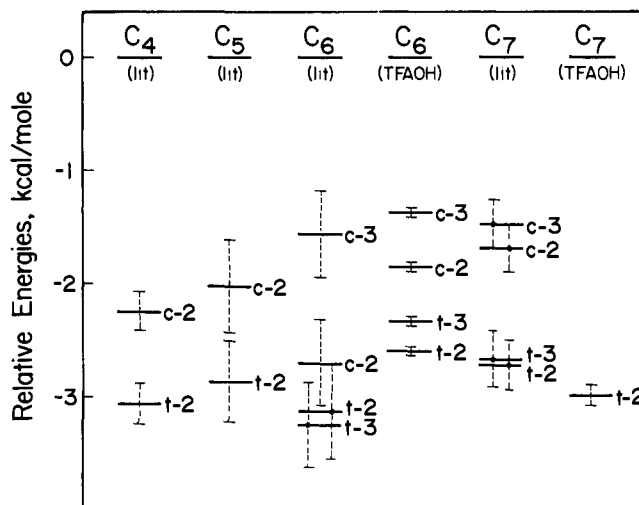

Figure 1. Graphical representation of the relative energies of the *n*-alkenes. All 1-alkenes are set equal to one another at zero. Uncertainty limits are represented by vertical dotted lines. The columns indicated by "lit" refer to combustion data, whereas those indicated by TFAOH refer to data from this work.

The results for 1-hexene are given in Table II. As expected, the precision of the results is considerably higher than that achieved for enthalpies of hydrogenation.⁴ The other *n*-hexenes were examined in a similar fashion, giving the data summarized in Table III. In each case, the composition of the ester mixture was determined 10 min after mixing, a time corresponding to the end of the reaction period. The ΔH values were corrected to correspond to the formation of an equilibrium mixture of the trifluoroacetates at 25 °C.

The enthalpies of formation of all five *n*-hexenes are known from enthalpy of combustion measurements¹⁷ (Table IV). Ideally, the trifluoroacetylation $\Delta\Delta H$ data should be combined with the combustion data in the least-squares sense in order to obtain the "best" values for the enthalpies of formation. However, our $\Delta\Delta H$ data differ from those in the literature by too much for this to be practical in the present case.

It is known that the reported enthalpies of formation of the 1-*n*-alkenes are linearly related to the number of carbons.²⁰ The agreement between calculated and observed values is shown in Table V. This gives one confidence that these enthalpies of formation are essentially correct. Thus, we have resorted to referring our $\Delta\Delta H$ values to that of 1-hexene. We have plotted the data²¹ for all of the *n*-alkenes from C₄ and through C₇ in Figure

(20) Prosen, E. J.; Johnson, W. H.; Rossini, F. D. *J. Res. Natl. Bur. Stand.* **1946**, *37*, 51.

Table VI. Enthalpies of Reaction of Water and Hexanols

compd	<i>n</i>	ΔH_f (cal/mol)	ΔH_{cor} (cal/mol) ^a
water	4	-18 007 ± 30	
2-hexanol	5	-21 415 ± 40	-21 351 ± 43
3-hexanol	9	-22 035 ± 48	-22 143 ± 50

^a Corrected to the equilibrium mixture.

1, placing the enthalpies of formation of the 1-*n*-alkenes at the same level. There are some clear trends in the data, and the reported enthalpies of formation for the *trans*-3-hexene and *cis*-2-hexene are almost surely incorrect.

Because of the large difference between the present results and those previously reported, the enthalpies of trifluoroacetylation of two of the *n*-heptenes²² also were determined, and the difference in enthalpy is included in Figure 1. The value has not been corrected for the small differences in product composition, but these corrections would be expected on the basis of the *n*-hexene data to be negligible on the scale of the figure. It can be seen that our data are in satisfactory agreement with the enthalpy of combustion data,²³ giving us confidence that our values are correct.

The data in Table V suggest that the enthalpy of formation of 1-hexene is known with a smaller uncertainty than has been reported. Thus, we have arbitrarily set the uncertainty as 200 cal/mol which is significantly greater than the deviation for the data in Table V. The enthalpies of formation of the other *n*-hexenes referred to 1-hexene are summarized in Table IV.

These data give some of the most precise values for the difference in enthalpy between *cis* and *trans* alkenes, and for the difference in enthalpy between mono- and disubstituted alkenes. For example, they show that ΔH for *cis*-*trans* isomerization for the 3-hexenes release 227 ± 74 cal/mol more than isomerization for the 2-hexenes. This trend is qualitatively repeated in the literature heptene data, but the precision is not great enough to make any quantitative conclusions. It appears that the measurement of enthalpies of trifluoroacetylation will provide a means for determining the enthalpy differences among many groups of isomeric alkenes with high precision, and will allow the study of more subtle structure-energy relationships than was possible before.

The second part of the determination of the enthalpies of hydration involves the measurement of the enthalpies of reaction of water and 2- and 3-hexanol with trifluoroacetic anhydride in the reaction medium. In the presence of a strong acid, these reactions are rather slow, presumably because water and the alcohols are converted to their conjugate acids which are no longer nucleophilic. The reaction did proceed satisfactorily in the absence of the acid catalyst, and thus the enthalpies were determined under these conditions. The results are presented in Table VI. Again, satisfactory precision was obtained.

Since the difference in enthalpy between the two trifluoroacetates in trifluoroacetic acid is known from the equilibration experiments, the difference in enthalpy between the two alcohols can be determined directly from the data, and is 792 ± 66 cal/mol.

In order to determine the enthalpies of hydration of the alkenes, it is necessary to have the same final state for the trifluoroacetylation of the alkenes and the esterification of the alcohols. However, as the experiments were performed, the first reaction was carried out in the presence of strong acid, whereas the latter was not. In order to correct the data to a common final state, the enthalpies of solution of the trifluoroacetates and trifluoroacetic acid were determined in the reaction solvent, both with and without trifluoromethanesulfonic acid. The results of these measurements are given in Table VII. The data may now be combined as is described in the Experimental Section to give the enthalpies of hydration and the enthalpies of formation of the alcohols (Table VIII).

(21) Pedley, J. B.; Rylance, J. "Sussex-N.P.L. Computer Analysed Thermochemical Data: Organic and Organometallic Compounds"; University of Sussex, 1977.

(22) The full data for the heptenes will be reported at a later time.

(23) Good, W. D. *J. Chem. Thermodyn.* 1976, 8, 67.

Table VII. Enthalpies of Solution of Trifluoroacetates and Trifluoroacetic Acid

compd	<i>n</i>	[H ⁺] (M)	ΔH_s (cal/mol)
TFAOH	1	0.002	-2
TFAOH	1	0.000	-17
ROTFA ^a	2	0.002	-1053 ± 43
ROTFA	2	0.000	-942 ± 22

^a An equilibrium mixture of 2-hexyl trifluoroacetate and 3-hexyl trifluoroacetate was used to prevent any heat due to equilibration in the calorimeter.

Table VIII. Enthalpies of Hydrolysis and Formation of Liquid 2-Hexanol and 3-Hexanol

compd	ΔH_{hyd} (cal/mol) ^a	ΔH_f (kcal/mol)	ΔH_f (kcal/mol) ¹⁸
2-hexanol	-8524 ± 76	-94.19 ± 0.21	-92.83 ± 0.4
3-hexanol	-7732 ± 81	-93.40 ± 0.21	

^a From the reaction 1-hexene + H₂O → hexanol.

This investigation has demonstrated the feasibility of determining the enthalpies of hydration of alkenes, and has shown the types of data which may result from such a study. We are investigating the hydration of a variety of alkenes, and we shall report the results at a later time.

Experimental Section

Reagents. Trifluoroacetic anhydride (TFA₂O) (Aldrich 99+% gold label) and trifluoromethanesulfonic acid (TFMSA) (Aldrich) were used without additional purification. 1-Hexene (99%) (Aldrich) was distilled prior to use. *cis*-2-Hexene, *cis*-3-hexene, and *trans*-3-hexene (99.5%) (Chemical Samples Co.) and *trans*-2-hexene (Aldrich 99+% gold label) were purchased in sealed ampules and were used without additional purification. *cis*-3-Hexene and *trans*-3-hexene (99%) (Chemical Samples Co.) were also purchased in bottles and distilled before use with no observed change in the value for the enthalpy. The only likely impurities were isomeric alkenes though none were detected by gas chromatography or NMR. 2-Hexanol and 3-hexanol (99%) (Chemical Samples Co.) were dried by heating to reflux over CaH₂ for a day and then distilling. In all distillations glassware was oven dried and the procedure was carried out under a positive pressure of dry nitrogen. A large forerun was allowed to wash through the apparatus before collecting the sample. Trifluoroacetic acid (TFAOH) (99%) (Baker) was used in the reaction solvent as described below.

Calorimetry samples were sealed in ampules which had been dried in an oven and cooled to room temperature in a desiccator before weighing. The calorimetry measurements were made as has been described before.¹⁹

Reaction Medium. The standard calorimetry solvent was 0.002 M TFMSA and 0.25 M TFA₂O in TFAOH. It was recycled after use. The solvent was prepared by dropwise distillation of used TFAOH through a 7-in. vacuum-jacketed, glass-helices-packed column separating the TFAOH (bp 72 °C) and TFA₂O (bp 40 °C) from the trifluoroacetates (bp 132 °C and TFMSA (bp 162 °C). The concentration of TFA₂ in the acid was determined by measuring its UV spectrum (λ_{max} 258 nm (ϵ 49)). It was made up to 0.25 M. To prepare solvent containing 0.002 M TFMSA, 0.09 mL of TFMSA was added to the solvent before making it up to 500 mL.

Hexyl Trifluoroacetates. The 2-hexyl trifluoroacetate and 3-hexyl trifluoroacetate were prepared identically except for the alcohol used. A two-necked 25-mL flask with a septum on one neck was flushed with dry nitrogen and cooled in an ice bath; 7.2 mL of TFA₂O (0.051 mol) was added. The flask was stirred magnetically, and 4.5 mL of 3-hexanol (0.036 mol) was slowly added through the septum. Once the addition was complete (~5 min) the mixture was allowed to stir at room temperature. After several hours the solution was distilled, the TFA₂O (bp 40 °C) and TFAOH (bp 72 °C) were discarded, and after a suitable forerun the 3-hexyl trifluoroacetate (bp 130–132 °C) or 2-hexyl trifluoroacetate (bp 134–135 °C) was collected. The NMR spectrum showed no alcohol or TFAOH was present.

Equilibration of Trifluoroacetates. Two NMR tubes containing 0.25 M TFA₂O and 0.5 M methanesulfonic acid in TFAOH were prepared. To one was added a mixture of 2-hexyl trifluoroacetate and 3-hexyl trifluoroacetate containing predominantly the 2 isomer. To the other was added a mixture containing predominantly the 3 isomer. Both tubes were sealed under vacuum and placed in a 40 °C bath. They were periodically checked by NMR until their spectra were identical (~2 weeks). Each tube was opened and the contents partitioned between methylene chloride

Scheme II

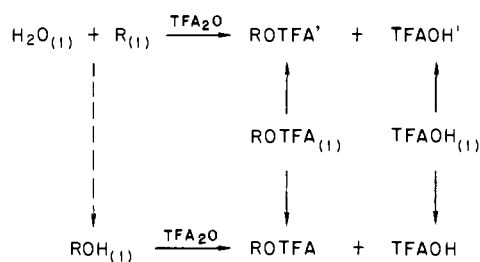

- (1) $\text{R}_{(1)} + \text{TFAOH}' + \text{TFA}_2\text{O}' + \text{S}' \rightarrow \text{ROTFA}' + \text{TFA}_2\text{O}' + \text{S}'$
- (2) $\text{H}_2\text{O}_{(1)} + \text{TFAOH} + \text{TFA}_2\text{O} + \text{S} \rightarrow 3\text{TFAOH} + \text{S}$
- (3) $\text{ROH}_{(1)} + \text{TFAOH} + \text{TFA}_2\text{O} + \text{S} \rightarrow \text{ROTFA} + 2\text{TFAOH} + \text{S}$
- (4) $\text{ROTFA}_{(1)} + \text{TFAOH} + \text{TFA}_2\text{O} + \text{S} \rightarrow \text{ROTFA} + \text{TFAOH} + \text{TFA}_2\text{O} + \text{S}$
- (5) $\text{ROTFA}_{(1)} + \text{TFAOH}' + \text{TFA}_2\text{O}' + \text{S}' \rightarrow \text{ROTFA}' + \text{TFAOH}' + \text{TFA}_2\text{O}' + \text{S}'$
- (6) $\text{TFAOH}_{(1)} + \text{TFAOH} + \text{TFA}_2\text{O} + \text{S} \rightarrow 2\text{TFAOH} + \text{TFA}_2\text{O} + \text{S}$
- (7) $\text{TFAOH}_{(1)} + \text{TFAOH}' + \text{TFA}_2\text{O}' + \text{S}' \rightarrow 2\text{TFAOH}' + \text{TFA}_2\text{O}' + \text{S}'$
- (1 + 2) $\text{R}_{(1)} + \text{H}_2\text{O}_{(1)} + \text{TFAOH}' + \text{TFA}_2\text{O} \rightarrow \text{ROTFA}' + 2\text{TFAOH}$
- 3) $\text{R}_{(1)} + \text{H}_2\text{O}_{(1)} + \text{TFAOH}' + \text{ROTFA} \rightarrow \text{ROTFA}' + \text{TFAOH} + \text{ROH}_{(1)}$
- + 4) $\text{R}_{(1)} + \text{H}_2\text{O}_{(1)} + \text{TFAOH}' + \text{ROTFA}_{(1)} \rightarrow \text{ROTFA}' + \text{TFAOH} + \text{ROH}_{(1)}$
- 5) $\text{R}_{(1)} + \text{H}_2\text{O}_{(1)} + \text{TFAOH}' \rightarrow \text{TFAOH} + \text{ROH}_{(1)}$
- 6) $\text{R}_{(1)} + \text{H}_2\text{O}_{(1)} + \text{TFAOH}' \rightarrow \text{TFAOH}_{(1)} + \text{ROH}_{(1)}$
- + 7) $\text{R}_{(1)} + \text{H}_2\text{O}_{(1)} \rightarrow \text{ROH}_{(1)}$

and saturated aqueous NaHCO_3 . The organic layer was washed with NaHCO_3 until the aqueous layer was basic, and then dried over MgSO_4 and filtered. This procedure was repeated for samples at 100 and 150 °C.

The ratio of 2-hexyl trifluoroacetate to 3-hexyl trifluoroacetate was measured using an F&M 700 gas chromatograph equipped with a 35 ft \times $1/8$ in. didecyl phthalate on 70/80 ABS column. Relative response factors were determined by preparing a known sample of 66.5% 2-hexyl trifluoroacetate and 33.5% 3-hexyl trifluoroacetate. The peak areas were integrated with a Varian CDS-111 digital integrator. The ratio of the peaks were measured with a precision of approximately 1% as indicated in Table I.

Product Ratio from Trifluoroacetylation. A drop of the appropriate hexene was added to an NMR tube containing the standard calorimetry solvent (0.002 M TFMSA). After 10 min its spectrum was measured using a Bruker HX270 spectrometer with homonuclear gated decoupling to suppress the solvent acid peak. Four transients were collected with a 10-s pulse delay. Three multiplets were used in the analysis: (a) δ 1.65, (b) δ = 1.4, and (c), δ 1.0. Standard samples were prepared with 2-hexyl trifluoroacetate/3-hexyl trifluoroacetate ratios of 1.34, 0.981, and 0.546 in solvent without TFMSA so that they would not isomerize. The peaks were digitally integrated and the ratios of their areas determined. The peak area ratio a:c was invariant with composition. By interpolation of the a:b and b:c area ratios the composition for each sample could be determined. Each sample was measured in duplicate, and all values were averaged to give those in Table III. The number of moles needed to convert the trifluoroacetate ratio to the equilibrium value of 1.68 was then multiplied by 172 cal/mol (from Table I) to give the correction factor for conversion of the enthalpy of reaction to formation of the equilibrium mixture.

Derivation of Enthalpy of Hydration. The enthalpy of hydration was calculated using the equations (in Scheme II) which take into account the differences in the reaction media used in the reactions of the alkenes and the alcohols. In the equations, R is an alkene, ROTFA is an equilibrium mixture of the trifluoroacetates, S is the reaction solvent minus 1 equiv of TFAOH and 1 equiv of TFA_2O , (l) indicates in the pure liquid state, and ' indicates in the presence of strong acid. A schematic diagram of the cycle used to derive the heat of hydration is shown in the Scheme. Following that is a rigorous derivation. The enthalpy of each of the reactions 1-7 was determined, and combined to give the enthalpy of hydration.

Acknowledgment. This investigation was supported by the Office of Basic Energy Science, Department of Energy.

Study of Increasingly Crowded Phenylethanes by ^{13}C NMR Spectroscopy and Molecular Mechanics Calculations

Michael I. Watkins and George A. Olah*

Contribution from the Hydrocarbon Research Institute and Department of Chemistry, University of Southern California, Los Angeles, California 90007. Received October 23, 1980

Abstract: An approach which characterizes the effect of nonbonded interactions on ^{13}C NMR shifts has been developed and applied to a complete series of phenylethanes. Force field calculations using Warshel's QCFF/PI + MCA program have been performed on the compounds to evaluate the nonbonded force on each atom used in the multiple regression analysis. X-ray crystal structure derived geometries reported in the literature have been used to compare with those obtained through calculation. The results show (1) experimental evidence for the polarization of electrons induced by nonbonded interactions, (2) the importance of steric interactions for all positions in a molecule, and (3) previously unobserved deshielding of the NMR signal of carbon due to steric compression of its bonds.

For many years¹ chemists have been keenly interested in studying the consequences of steric interactions in molecules. When two nonbonded atoms come to within the sum of their van der Waals radii of each other, they repulse one another. These atoms will in turn distort from their ideal geometry in an optimum

way so as to reduce this repulsion without sacrificing too much in the way of bonding energy. Ethane substituted by phenyl groups has been a focal point for this field of interest² which began when Gomberg in 1900³ proposed that "hexaphenylethane" dissociated readily to give the triphenylmethyl radical due to the large degree of strain placed on the ethane C-C bond. More recent investigators have utilized molecular mechanics,⁴ X-ray structure de-

(1) For a recent review see: (a) Tidwell, T. T. *Tetrahedron* 1978, 34, 1855-1868. (b) Forster, H.; Vogtle, F. *Angew. Chem.* 1977, 89, 443-455. (c) Liebman, J. F.; Greenberg, A. *Chem. Rev.* 1976, 76, 311-365. (d) Voronkov, V. V.; Osokin, Y. G. *Russ. Chem. Rev. (Engl. Transl.)* 1972, 41, 616-629.

(2) (a) Lankamp, H.; Nauta, W. T.; MacLean, C. *Tetrahedron Lett.* 1968, 249-254. (b) McBride, J. M. *Tetrahedron* 1974, 30, 2009-2022. (3) Gomberg, M. *J. Am. Chem. Soc.* 1900, 22, 757-771.